



CASAMBI



DMX

## FEATURES

- ◆ CASAMBI<sup>®</sup>-to-DMX PROTOCOL CONVERTER
- ◆ Signal converter from CASAMBI<sup>®</sup> to DMX
- ◆ Input voltage: 230 Vac @50/60 Hz
- ◆ Remote control: via Bluetooth Low Energy (BLE)
- ◆ Local control: Normally Open (N.O.) push-button
- ◆ Configuration and control via CASAMBI<sup>®</sup> mobile application
- ◆ Extended Temperature Range
- ◆ 100% Functional Test - 5 years warranty

## PRODUCT DESCRIPTION

SLIM-CBU-DMX is a CASAMBI<sup>®</sup> Bluetooth Unit (CBU) designed to function as protocol converter between CASAMBI<sup>®</sup> and DMX networks. In Master mode, the CBU receives a command from CASAMBI<sup>®</sup> Mesh network or mobile app and converts it into a DMX command signal; in Slave mode, the CBU receives a command signal from DMX bus and translate it into a command on CASAMBI<sup>®</sup> Mesh network (sent over BLE).

Both operating modes Master and Slave can be managed via CASAMBI<sup>®</sup> mobile app (refer to [§Profiles Overview: Fixtures](#) for Master/Slave conversion profiles).

The device operates on Mains voltage 230 Vac @50/60 Hz power supply and features built-in logic control protections, including overvoltage and input-fuse protections.

Through the CASAMBI<sup>®</sup> mobile application and smartphones equipped with Bluetooth technology, it is possible to configure multiple values. CASAMBI<sup>®</sup> mobile application can be downloaded free of charge from the Apple APP Store and Google Play Store.

→ For the most up-to-date manual, please visit our website [www.dalcnet.com](http://www.dalcnet.com) or scan the QR code on product label.

→ For the correct functioning of the CASAMBI<sup>®</sup> mobile app, please visit the forum on the Casambi website:

<https://support.casambi.com/support/home>



## PRODUCT CODE

CODE	POWER SUPPLY	MODE	REMOTE CONTROL	OUTPUT	CONFIGURATION
SLIM-CBU-DMX	230 Vac @50/60 Hz	Master	CASAMBI <sup>®</sup> Mesh or Mobile app (BLE)	DMX	CASAMBI <sup>®</sup> Mobile app
		Slave	DMX	CASAMBI <sup>®</sup> Mesh (BLE)	

Table 1: Product code

## PROTECTIONS AND DETECTION

The following table shows the types of ingress and egress protection/detection present on the device.

ACRONYM	DESCRIPTION	TERMINAL	PRESENT
<b>OVP</b>	Over Voltage Protection <sup>1</sup>	AC IN	✓
<b>IFP</b>	Input Fuse Protection <sup>1</sup>	AC IN	✓

Table 2: Protection and Detection features

## REFERENCE STANDARDS

STANDARD	TITLE
<b>ANSI E1.11</b>	Entertainment Technology - USITT DMX512-A - Asynchronous Serial Digital Data Transmission Standard for Controlling Lighting Equipment and Accessories

Table 3: Reference standards

## TECHNICAL SPECIFICATIONS

Description	Acronym	Values			Units of Measure	Note
		Min	Typ	Max		
<b>INPUT (AC IN)</b>						
Nominal Supply Voltage	V <sub>IN</sub>	230			Vac	-
Supply Voltage range	V <sub>IN-RNG</sub>	100	÷	240	Vac	-
Mains frequency	f <sub>MAINS</sub>	50	or	60	Hz	-
Standby power absorption	P <sub>STBY</sub>	< 0.5			W	-
Rated power absorption (max)	P <sub>ABS-max</sub>	2			W	@230 Vac
<b>OUTPUT BUS (DMX)</b>						
No. of DMX Channels	-	Slave	Master		-	Adjacent channels
	DMX <sub>SIZE</sub>	8	12		-	
RDM Support	RDM	Not supported			-	-
<b>ENVIRONMENTAL</b>						
Operating Frequencies <sup>2</sup>	f <sub>OP</sub>	2402	÷	2480	MHz	For CASAMBI® BLE SoC
Maximum Emitted Power <sup>2</sup>	P <sub>BT-max</sub>	8			dBm	Over Bluetooth transmission
Storage Temperature	T <sub>STOCK</sub>	-40	÷	+60	°C	Minimum values defined by design
Working Ambient temperature <sup>3</sup>	T <sub>A</sub>	-25	÷	+60	°C	Minimum values defined by design
Connector Type	C <sub>TYPE</sub>	Push-in terminals			-	-
Wiring Section	WS <sub>SOLID</sub>	0.5	÷	1.5	mm <sup>2</sup>	-
	WS <sub>STRAND</sub>	20	÷	16	AWG	
Strip length	WS <sub>STRIP</sub>	10			mm	-
Protection class	IP <sub>CODE</sub>	IP20			-	-
Enclosure Material	M <sub>CASE</sub>	PC/ABS			-	Polycarbonate/ABS
Packaging unit (pieces/units)	UP	1			pcs	-
Dimensions	-	L	A	P	-	-
	MD	136	29	21	mm	Enclosure
	PD	147	34	29	mm	Packaging
Weight	W	62			g	Imballaggio incluso

Table 4: Technical specifications

<sup>1</sup> Protections refer to the control logic of the board.

<sup>2</sup> The parameters are derived from the configuration of the Casambi module.

<sup>3</sup> Depends on ventilation conditions

## INSTALLATION



**WARNING!** Installation and maintenance must always be carried out in the absence of voltage.

Before proceeding with the connection of the device to the power supply, make sure that the voltage of the power source is disconnected from the system.



The device should only be connected and installed by qualified personnel. All applicable regulations, legislation, standards, and building codes must be adhered to. Incorrect installation of the device may cause irreparable damage to the device and connected loads.

Following paragraphs show the diagrams of the module power supply and Bus connections. It is recommended to follow these steps to install the product safely.



- Safety first:** ensure the Mains Supply is disconnected before starting the installation.
- Electrical connections:** connect the electrical wires to the terminals of the device following the next instructions.
  - Bus wiring:** wire the signals DATA+, DATA- and COMMON of the data bus to the "DMX" terminals respectively with the symbols "D+" "D-" "COM" (both of "COM" terminals can be used).
  - Local control wiring:** wire a N.O. push-button to the "PUSH" terminal with the symbol . Make sure not to connect any live parts to the PUSH terminals.
  - Power supply wiring:** connect the 230 Vac @50/60 Hz Mains voltage "L" (Live) and "N" (Neutral) wires to the AC IN terminal.



- Check the connections:** verify that all connections are tightly secured and that there are no exposed wires.
- Final check:** reconnect the Mains voltage and power ON the device. Perform a test to ensure that the device is functioning correctly and that all connections are secure.

*Note: the installer is responsible for verifying the installation.*

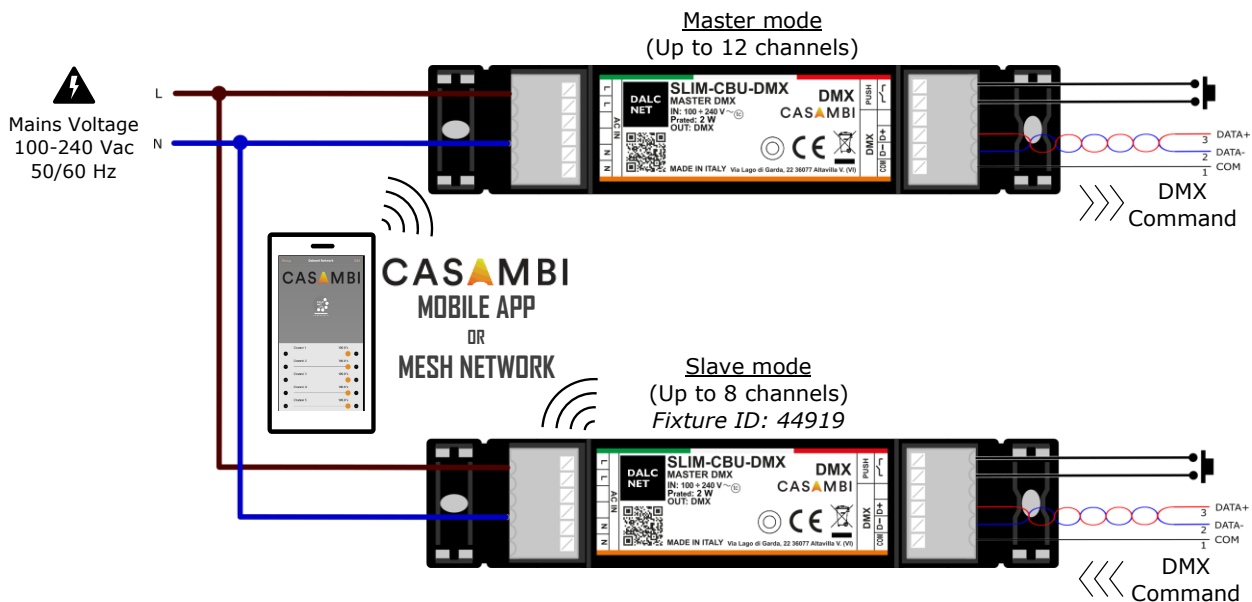

Figure 1: Wiring diagram

### BUS WIRING: DMX NETWORK

SLIM-CBU-DMX can communicate over DMX digital bus by means of a three-wire, twisted and shielded cable, with a nominal impedance of 110 Ω.



To connect SLIM-CBU-DMX to the DMX network, simply connect the bus cables to the terminals of the "DMX" terminal: since no other topologies other than Bus-wiring are possible, the polarity of the "COM", "D+" and "D-" signals must be respected during connection.

The most commonly used connectors are 3 and 5 pole XLR, where one pin is the cable shield (ground) and 2 pins are used for DMX signal transmission. In the case of 5-pole XLR, the other 2 pins are reserved for a secondary DMX balanced line<sup>4</sup>.

Signal Description	Pin# (3-Pin XLR)	Pin# (5-Pin XLR)	DMX Function
Common Reference	1	1	Data-Link Common
Primary Data-Link	2	2	Data 1-
	3	3	Data 1+
Secondary Data-Link <sup>4</sup>	-	4	Data 2-
	-	5	Data 2+

Table 5: Three and Five pin XLR connector pinouts

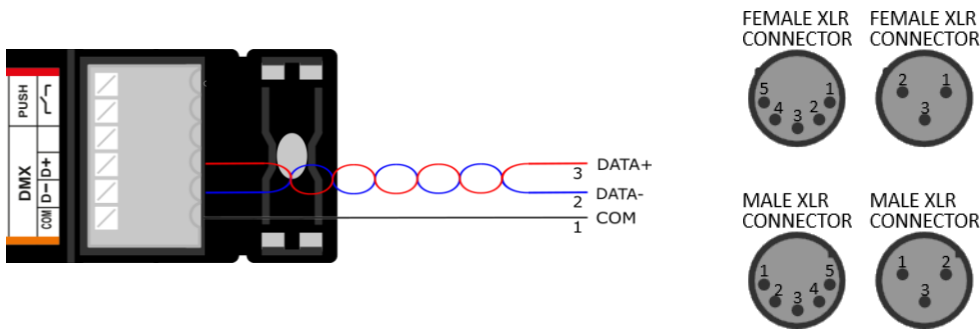

Figure 2: Bus Connection Pin-out and XLR Connectors

**DMX WIRING TOPOLOGY**

DMX protocol requires a single wiring topology, Bus-wiring, which is shown as an example in Figure 3 (DMX Master mode) and Figure 4 (DMX Slave mode).

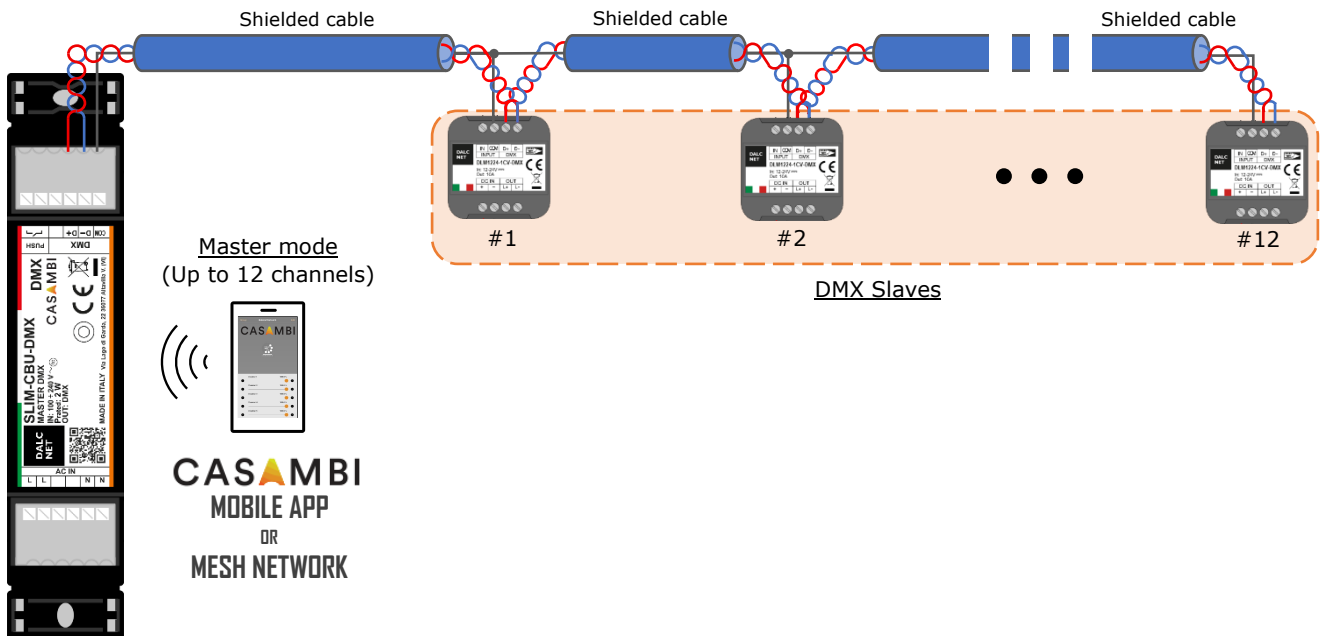

Figure 3: DMX Master, Bus-wiring Topology

<sup>4</sup> Optional, refer to chapter §4.8 of ANSI E1.11.

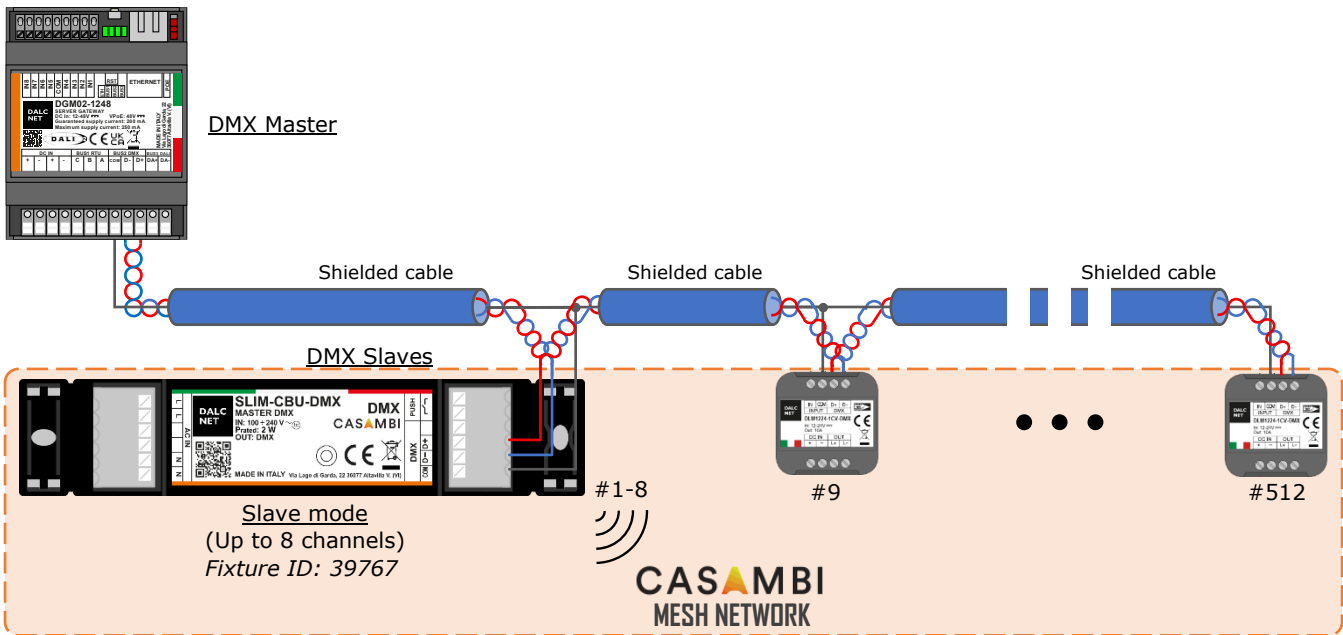



Figure 4: DMX Slave, Bus-wiring Topology

### LOCAL COMMAND WIRING

SLIM-CBU-DMX can be controlled via Local Command with a Normally Open (N.O.) pushbutton or voltage-free dry contact. No other voltage signals shall be applied to these contacts.

 To connect the SLIM-CBU-DMX to local command, simply connect the pushbutton to the INPUT terminal. The following image shows the indicated connection diagram for short distances (<10 m).

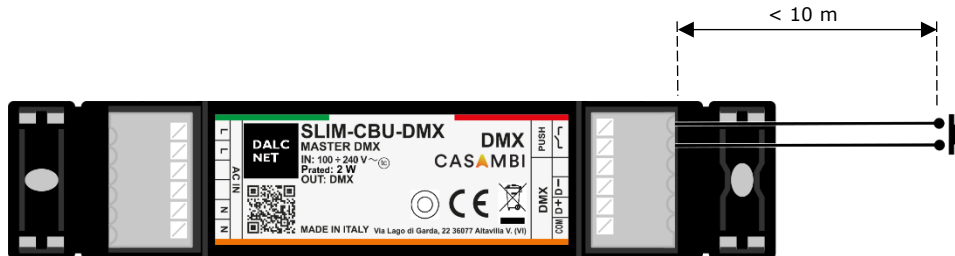



Figure 5: Local Command connection diagram for Short Distances

### MAINS VOLTAGE SUPPLY WIRING

 SLIM-CBU-DMX can be powered by 230 Vac @50/60 Hz Mains voltage supply. Once bus and local control are wired, connect the Mains voltage supply respecting the polarity conventions to the Live (L) and Neutral (N) labels of the AC IN terminal.

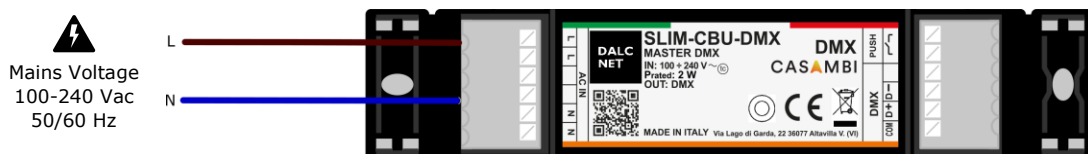

Figure 6: Mains voltage Supply wiring Diagram

## LOCAL COMMAND: PUSHBUTTON

SLIM-CBU-DMX has one dry contacts input for N.O. pushbutton, through which different operating parameters can be managed. Each action on the pushbuttons activates a specific function for the type of control selected via CASAMBI® mobile app. For all other functions consult the documentation of the CASAMBI® mobile app at: <https://support.casambi.com/support/home>

### PUSHBUTTON FUNCTIONALITY FOR "CONTROLS A LUMINAIRE"

In *Controls a Luminaire* mode, both connected buttons take over ON/OFF control and luminaire brightness functions.



ACTION	FUNCTION
 Quick press	Turn ON/OFF the selected Luminaire
 Long press (> 1s)	Brightness adjustment (Dimming)

Table 6: Pushbutton functionality for "Controls a Luminaire"

### PUSHBUTTON FUNCTIONALITY FOR "CONTROLS AN ELEMENT"

In *Controls an Element* mode, the pushbuttons take over ON/OFF control functions dedicated to a device element inside the CASAMBI® network and to adjust the element value.



ACTION	FUNCTION
 Quick press	Turn ON/OFF of the selected device element
 Long press (> 1s)	Element value adjustment

Table 7: Pushbutton functionality for "Control an Element"

### PUSHBUTTON FUNCTIONALITY FOR "CONTROL A GROUP"

In *Control a Group* mode, the connected buttons take on functions dedicated to control a group of LED modules and their brightness adjustment.



ACTION	FUNCTION
 Quick press	Turn ON/OFF the configured Group of devices
 Long press (> 1s)	Brightness adjustment (Dimming)

Table 8: Pushbutton functionality for Control a Group"

### PUSHBUTTON FUNCTIONALITY FOR "CONTROL SCENE"

In *Control scene* mode, the buttons take over brightness adjustment and ON/OFF of the programmed scenario.



ACTION	FUNCTION
 Quick press	Turn ON/OFF the configured Scene
 Long press (> 1s)	Brightness adjustment (Dimming)

Table 9: Pushbutton functionality for "Control scene"

## PUSHBUTTON FUNCTIONALITY FOR "CONTROL ALL LUMINAIRES"

In *Control all Luminaires* mode, both connected buttons take over ON/OFF control and brightness functions of all luminaires.



ACTION	FUNCTION
 Quick press	Turn ON/OFF all the Luminaires
 Long press (> 1s)	Brightness adjustment (Dimming)

Table 10: Pushbutton functionality for "Controls all Luminaires"

## PUSHBUTTON FUNCTIONALITY FOR "CYCLES SCENES"

In *Cycles scenes* mode, the buttons take over brightness adjustment and selection through the programmed scenario list.



ACTION	FUNCTION
 Quick press	Cycle through the list of scenes
 Long press (> 1s)	Brightness adjustment of current scene (Dimming)

Table 11: Pushbutton functionality for "Cycle scenes"

## PUSHBUTTON FUNCTIONALITY FOR "ACTIVE/STANDBY"

In *Active/Standby* mode, the buttons take over brightness adjustment and selection between two programmed scenes.



ACTION	FUNCTION
 Quick press	Switch between two programmed scenes
 Long press (> 1s)	Brightness adjustment of current scene (Dimming)

Table 12: Pushbutton functionality for "Active/Standby"

## DMX PROTOCOL

The DMX protocol (or DMX512) is a digital communication standard used primarily for controlling stage lighting in the entertainment industry and allows numerous lights and effects to be controlled from a control room. Recently, it has also been introduced in architectural lighting. The DMX is based on the physical RS-485 protocol: an RS485 industrial line, i.e. a shielded bipolar cable with a nominal impedance of 110Ω, is therefore used to connect a DMX controller to compatible equipment.

The DMX protocol provides for different profiles, depending on the light characteristics to be obtained through the LED module connected to the CASAMBI® dimmers.

Each profile is composed of a defined number of 8-bit channels, whose values can be set in the range (0 ÷ 255), each of which represents a light characteristic (e.g. brightness, colour, saturation, etc.) to be modulated on the LED load.

## REMOTE CONTROL & CONFIG.: CASAMBI®

CASAMBI® is a lighting control system based on Bluetooth Low Energy (BLE) technology. This technology allows for the creation of customized and flexible wireless lighting networks that can be easily configured and controlled via Android/iOS devices.

### PROFILES OVERVIEW: FIXTURES

PROFILE NAME	PROFILE ID	DESCRIPTION
DMX SLAVE 8CH – SLIM CBU DMX	44919	<b>DMX Slave mode</b> CASAMBI® devices control (up to 8 adjacent channels) from DMX network. Provides controls to set the DMX starting address and refresh rate.
W – SLIM CBU DMX	45143	<b>One channel DMX dimmer</b> - Dimmer 1: channel 1
4xW – SLIM CBU DMX	45144	<b>Four channels DMX dimmer</b> - Dimmer 1: channel 1 - Dimmer 2: channel 2 - Dimmer 3: channel 3 - Dimmer 4: channel 4
<b>8xW – SLIM CBU DMX</b>	<b>45145 (Default)</b>	<b>Eight channels DMX dimmer</b> - Dimmer 1: channel 1 - Dimmer 2: channel 2 - Dimmer 3: channel 3 - Dimmer 4: channel 4 - Dimmer 5: channel 5 - Dimmer 6: channel 6 - Dimmer 7: channel 7 - Dimmer 8: channel 8
12xW – SLIM CBU DMX	44917	<b>Twelve channels DMX dimmer</b> - Dimmer 1: channel 1 - Dimmer 2: channel 2 - Dimmer 3: channel 3 - Dimmer 4: channel 4 - Dimmer 5: channel 5 - Dimmer 6: channel 6 - Dimmer 7: channel 7 - Dimmer 8: channel 8 - Dimmer 9: channel 9 - Dimmer 10: channel 10 - Dimmer 11: channel 11 - Dimmer 12: channel 12
Tunable White 2CH – SLIM CBU DMX	45146	<b>Two channels (Tunable White) DMX dimmer</b> - Warm White Dimmer: channel 1 - Cool White Dimmer: channel 2
RGB – SLIM CBU DMX	45147	<b>Three channels (RGB) DMX dimmer</b> - Red Dimmer: channel 1 - Green Dimmer: channel 2 - Blue Dimmer: channel 3
RGBW – SLIM CBU DMX	45148	<b>Four channels (RGBW) DMX dimmer</b> - Red Dimmer: channel 1 - Green Dimmer: channel 2 - Blue Dimmer: channel 3 - White Dimmer: channel 4
RGB+TW – SLIM CBU DMX	45149	<b>Five channels (RGB + Tunable White) DMX dimmer</b> - Red Dimmer: channel 1 - Green Dimmer: channel 2 - Blue Dimmer: channel 3 - Warm White Dimmer: channel 4 - Cool White Dimmer: channel 5

PROFILE NAME	PROFILE ID	DESCRIPTION
MRGBS – SLIM CBU DMX	45150	<b>Five channels (Master + RGB + Strobe) DMX dimmer</b> <ul style="list-style-type: none"> <li>- Master Dimmer: channel 1</li> <li>- Red Dimmer: channel 2</li> <li>- Green Dimmer: channel 3</li> <li>- Blue Dimmer: channel 4</li> <li>- Strobe Rate Channel: channel 5</li> </ul>
MRGBWS – SLIM CBU DMX	45151	<b>Six channels (Master + RGBW + Strobe) DMX dimmer</b> <ul style="list-style-type: none"> <li>- Master Dimmer: channel 1</li> <li>- Red Dimmer: channel 2</li> <li>- Green Dimmer: channel 3</li> <li>- Blue Dimmer: channel 4</li> <li>- White Dimmer: channel 5</li> <li>- Strobe Rate Channel: channel 6</li> </ul>

Table 13: Profile list

## PROFILE MAPPING

Each Profile can be configured on CASAMBI® mobile application with the proper DMX Starting address (refer to [§Change Profile on Paired device](#) section of this document) and other parameters depending to the selected profile.

### DMX SLAVE 8CH: 8 CHANNELS DMX (SLAVE MODE)

Use this profile to control up to 8 CASAMBI® devices from 8 adjacent channels on DMX network, with the proper DMX Starting address and refresh rate of DMX bus. Configuration from CASAMBI® mobile application.

#### W: 1 CHANNEL

The "W" profile allows you to adjust the DMX level for one independent channel.

DMX Ch.	Function	Level
1	DIMMER 1	0...255

#### 4xW: 4 CHANNELS

The "WWW" profile allows you to adjust the DMX level of up to four independent channels.

DMX Ch.	Function	Level
1	DIMMER 1	0...255
2	DIMMER 2	0...255
3	DIMMER 3	0...255
4	DIMMER 4	0...255

#### 8xW: 8 CHANNELS (DEFAULT)

The "8xW" profile allows you to adjust the DMX level of up to eight independent channels.

DMX Ch.	Function	Level
1	DIMMER 1	0...255
2	DIMMER 2	0...255
3	DIMMER 3	0...255
4	DIMMER 4	0...255
5	DIMMER 5	0...255
6	DIMMER 6	0...255
7	DIMMER 7	0...255
8	DIMMER 8	0...255

### 12xW: 12 CHANNELS

The "12xW" profile allows you to adjust the DMX level of up to twelve independent channels.

DMX Ch.	Function	Level
1	DIMMER 1	0...255
2	DIMMER 2	0...255
3	DIMMER 3	0...255
4	DIMMER 4	0...255
5	DIMMER 5	0...255
6	DIMMER 6	0...255
7	DIMMER 7	0...255
8	DIMMER 8	0...255
9	DIMMER 9	0...255
10	DIMMER 10	0...255
11	DIMMER 11	0...255
12	DIMMER 12	0...255

### TUNABLE WHITE 2CH: WARM/COLD WHITE INDEPENDENT DIMMERS

With the "Tunable White" profile, the Warm White and Cold White values are regulated via two independent DMX channels.

DMX Ch.	Function	Level
1	WARM WHITE DIMMER	0...255
2	COLD WHITE DIMMER	0...255

### RGB

Through the "RGB" profile it is possible to adjust the intensity of the primary colours Red-Green-Blue through three independent DMX channels.

DMX Ch.	Function	Level
1	RED DIMMER	0...255
2	GREEN DIMMER	0...255
3	BLUE DIMMER	0...255

### RGBW

Like to the "RGB", the "RGBW" profile allows the intensity of the Red-Green-Blue primary colours to be adjusted through three independent DMX channels and in addition the white light adjustment on a dedicated DMX channel.

DMX Ch.	Function	Level
1	RED DIMMER	0...255
2	GREEN DIMMER	0...255
3	BLUE DIMMER	0...255
4	WHITE DIMMER	0...255

### RGB+TW

The "RGB+TW" profile allows the intensity of the Red-Green-Blue primary colours to be adjusted through three independent DMX channels and in addition the Warm White and Cold White light adjustment on a dedicated DMX channels.

DMX Ch.	Function	Level
1	RED DIMMER	0...255
2	GREEN DIMMER	0...255

DMX Ch.	Function	Level
3	BLUE DIMMER	0...255
4	WARM WHITE DIMMER	0...255
5	COLD WHITE DIMMER	0...255

#### MRGBS: MASTER + RGB + STROBE

The "MRGBS" profile allows to change light parameters over 5 DMX channels, one of which is for adjusting the light intensity (Master dimmer), three channels for adjusting the primary colours Red-Green-Blue and one channel to set the Strobe effect.

DMX Ch.	Function	Level
1	MASTER DIMMER	0...255
2	RED DIMMER	0...255
3	GREEN DIMMER	0...255
4	BLUE DIMMER	0...255
5	STROBE RATE <sup>5</sup>	0...255

#### MRGBWS: MASTER + RGBW + STROBE

Like the "MRGBS", the "MRGBWS" profile allows to change light parameters over 6 DMX channels, one for the light intensity (Master dimmer), three channels to adjust the primary colours Red-Green-Blue, one channel to set the Strobe effect and a dedicated DMX channel for the white light adjustment.

DMX Ch.	Function	Level
1	MASTER DIMMER	0...255
2	RED DIMMER	0...255
3	GREEN DIMMER	0...255
4	BLUE DIMMER	0...255
5	WHITE DIMMER	0...255
6	STROBE RATE <sup>5</sup>	0...255

<sup>5</sup> The "Strobe Rate" channel is a standard DMX channel that outputs a value between 0 and 255 dedicated to the strobe function of the lighting control unit connected to the SLIM-CBU-DMX. It does not represent a direct control channel for the strobe, nor does it generate a strobe effect on the other channels. The generation of the effect, depending on the value on this channel, is always delegated to the connected lighting control unit. Check the behavior associated with this channel on the lighting control unit.

## MECHANICAL DIMENSIONS

Following figure details the mechanical measurements and overall dimensions [mm] of the outer casing.

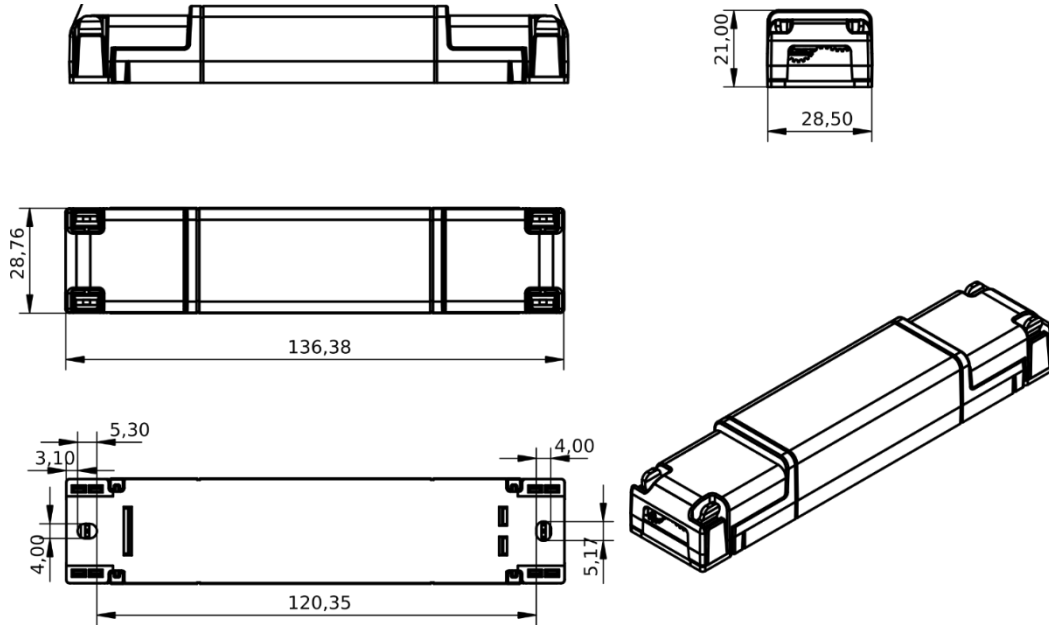

Figure 7: Mechanical dimensions

## TECHNICAL NOTES

### INSTALLATION



**WARNING!** Installation and maintenance should always be performed in the absence of AC voltage. Before proceeding with the installation, adjustment, and connection of the device to the Mains supply, make sure that the Mains voltage is disconnected and/or isolated from the system.



The device should only be connected and installed by qualified personnel. All applicable regulations, legislation, standards, and building codes in force in the respective countries must be adhered to. Incorrect installation of the device may cause irreparable damage to the device and connected loads.

Maintenance must only be carried out by qualified personnel in compliance with current regulations.

The product must be installed inside an electrical panel and/or junction box that is protected against surges/overvoltage and not shielded.

The product is suitable for use in dry places, away from sources of moisture. Installation and use must take place in a dry environment.

Keep 230 Vac (LV) circuits and non-SELV circuits separate from SELV safety ultra-low voltage circuits and any product connections.

The product must be installed in a vertical or horizontal position, i.e. with the faceplate/label/top cover facing up or vertically. No other positions are allowed. The bottom position, i.e. with the faceplate/label/top cover facing downwards, is not allowed.

During installation, it is recommended to reserve adequate space around the device to facilitate its accessibility in case of future maintenance or updates (e.g. via smartphone).



Use in thermally harsh environments may limit the output power of the product.

For devices embedded within luminaires, the  $T_A$  ambient temperature range is a guideline to be carefully observed for the optimal operating environment. However, the integration of the device within the luminaire must always ensure proper thermal management (e.g. correct mounting of the device, proper ventilation, etc.) so that the temperature at the  $T_C$  point does not exceed its maximum limit under any circumstances. Proper operation and durability are only guaranteed if the maximum temperature of the  $T_C$  point is not exceeded under the conditions of use.

### POWER SUPPLY AND CONTROLS



The device must be powered only with Mains voltage supply with limited current at constant voltage, short circuit protection and power suitably sized according to the specifications indicated in the product data sheet. No other types of power supplies are allowed.

The external supply must be protected. The product must be protected by a properly sized Miniature Circuit Breaker (MCB) with overcurrent protection.

Connecting to an unsuitable power supply may cause the device to operate outside of the specified design limits, voiding its warranty.

In the case of power supplies equipped with earth terminals, it is mandatory to connect ALL the protection earth points (PE= Protection Earth) to a state-of-the-art and certified earthing system.

The power cables of the device must be correctly sized with reference to the connected load and must be isolated from any wiring or equal to non-SELV voltage. Use double-insulated cables.

The manufacturer recommends ensuring a cumulative leakage current of less than 3.5 mA on the control circuit.



It is strictly forbidden to connect, for any reason, directly or indirectly, any type of Voltage supply to the terminals of the BUS.

The length and type of bus connection cables must comply with the specifications of the respective protocols (i.e. by means of a three-wire, twisted and shielded cable, with a nominal impedance of 110  $\Omega$ ) and current regulations. They must be isolated from any wiring or non-SELV live parts. It is recommended to use double-insulated cables.

All control devices and signals connected to the buses must be of the SELV type (the connected devices must be SELV or in any case provide a SELV signal).



It is strictly forbidden to connect, for any reason, directly or indirectly, any type of Voltage supply to the PUSH terminals.

All devices and control signals connected to local commands with the symbol  must not supply any type of voltage.

The length of the connection cables between the local controls (N.O. buttons) and the product must be less than 10m. The cables must be sized correctly. Depending on the connection used, they must be isolated from any wiring or non-SELV voltage parts. It is recommended to use double-insulated cables, if deemed appropriate, also shielded.

### BLUETOOTH LOW ENERGY (BLE) WARNINGS AND MOBILE APP NOTES



The BLE antenna is located inside the device.

BLE typically has a range of about 10 to 50 meters, depending on the environment and obstacles. Ensure your devices are within this range for reliable communication.

Walls, floors, and other physical barriers can significantly reduce the effective range and signal strength of BLE devices. Position devices to minimize these obstacles.

Other electronic devices, especially those operating on the 2.4 GHz frequency (like Wi-Fi routers), can interfere with BLE signals. Keep BLE devices away from such sources of interference.

Ensure that all devices in your BLE network are compatible with each other and support the same BLE version. Incompatibilities can lead to communication issues.

BLE is designed for low power consumption, but the battery life of your control devices (smartphone or tablet) can still be affected by factors like transmission frequency and data volume. Monitor and manage power settings to optimize battery life.

BLE technology works optimally with non-metallic materials. Therefore, it is not recommended to surround the device by metal objects or reflective surfaces when using BLE communication.

For reliable communication, make sure that the top surface is not covered or that it is free of metal objects, wiring, or other electronic devices. Any impediments could affect the quality of communication.



To guarantee the best performances and the full use of functions, make sure to download on your device the last release of CASAMBI® mobile app.

Whenever CASAMBI® mobile app requires an upgrade of the profile installed in the product, follow the instruction to do it. This allows you to stay always up to date and benefit of new functions released.

Functionality test are done on all devices to ensure the right working. In case the device is still paired to "Dalcnet network", you are asked to unpair it by following the instructions on CASAMBI® mobile app and in [§Unpair device from CASAMBI® Network](#) section.

## LEGAL NOTES



### TERMS OF USE

 Dalcnet Srl (hereinafter referred to as "the Company") reserves the right to make changes to this device, in whole or in part, without prior notice to the customer. Such changes may affect technical aspects, functionality, design, or any other element of the device. The company is not required to notify you of such changes and that your continued use of the device will constitute your acceptance of the changes.

The company is committed to ensuring that any changes do not compromise the essential functionality of the device and that they comply with applicable laws and regulations. In the event of substantial changes, the company undertakes to provide clear and timely information on the same.

The customer is advised to periodically consult the [www.dalcnet.com](http://www.dalcnet.com) website or other official sources to check for any updates or changes to the device.

## SYMBOLS

	<p>All products are manufactured in compliance with European Regulations, as reported in the Declaration of Conformity.</p>
	<p>Integrated electronic ballast with double or reinforced insulation, designed to be used as a component of an end product.</p>
	<p>At the end of its useful life, the product described in this data sheet is classified as waste from electronic equipment and cannot be disposed of as unsorted municipal solid waste. <b>Warning!</b> Improper disposal of the product may cause serious harm to the environment and human health. For proper disposal, inquire about the collection and treatment methods provided by the local authorities.</p>

## CASAMBI



CASAMBI® is the official application through which it is possible to configure, in addition to the functions of the SLIM-CBU-DMX, also all the different CASAMBI® products equipped with BLE technology.

CASAMBI® mobile app can be downloaded free of charge from the Apple App Store and Google Play Store.



## DEVICE SETTINGS

### PAIR DEVICE TO CASAMBI® NETWORK

The first time you turn ON a SLIM-CBU-DMX device, it will appear in the "Found a new device" section with the default profile preloaded. Perform the following procedure to Pair the device to a CASAMBI® Network.

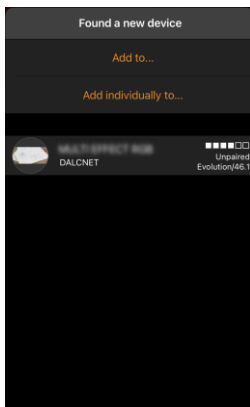

1. Open the CASAMBI® mobile app and Power ON the device. The device to be paired will appear.
2. Select "Add to..." to open the list of available networks.

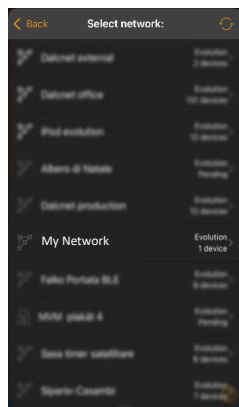

3. Select the network to pair the device with.

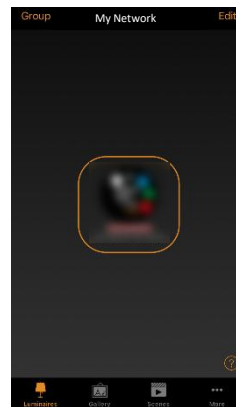

4. Once the device has been inserted in the Network, the default profile will be loaded.

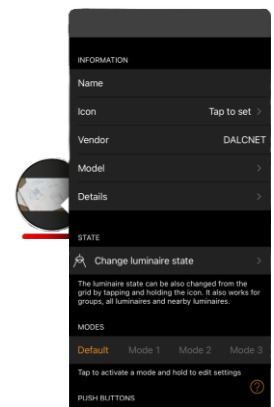

5. Double tap on the profile icon to show the device configuration.

### UNPAIR DEVICE FROM CASAMBI® NETWORK

If SLIM-CBU-DMX is already connected to a known network and/or you wish to associate it with a new network, you need to unpair the device from the current Network first: please tap the device icon from *Nearby Devices* section, select *Unpair*, and confirm. The unpair process will be started. After the unpairing, the device can be paired to a new Network by following the instructions on above section.

To unpair a device already connected to an unknown Network (for which you don't have the credentials), please follow these steps:

1. Tap the device icon from *Nearby Devices* section, select *Unpair*, and confirm.
2. During the unpair process, turn OFF the Power Supply connected to the SLIM-CBU-DMX.
3. Wait 1-2 seconds, then turn the Power Supply ON again.
4. On *Nearby Devices* section the device will be shown as unpaired.

*Note: if the power supply is switched OFF and ON again quickly, unpair may not be done properly. Repeat the unpair sequence by allowing 1 or 2 more seconds to elapse between the moment you turn OFF and re-turn ON the Power Supply.*

Another method to unpair the device from an unknown Network can be performed using a N.O. push-button connected to the "INPUT" terminal of the SLIM-CBU-DMX, following the next steps:

1. Tap the device icon from *Nearby Devices* section, select *Unpair*, and confirm.
2. During the unpair process, quick press the N.O. push-button.
3. After a while, on *Nearby Devices* section the device will be shown as unpaired.

## CHANGE PROFILE ON PAIRED DEVICE

Once the technical data of the load to be connected to the device have been verified, it is possible to configure the date and time parameters for the selected profile by loading the Fixture on the controller. To change the Fixture on the SLIM-CBU-DMX, follow these steps.

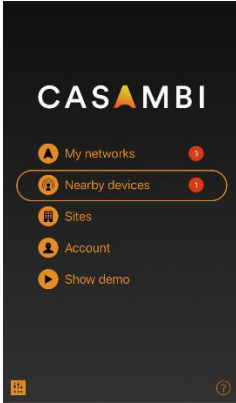

1. Power ON the device and open the CASAMBI® mobile app.
2. Select *Nearby Devices*.

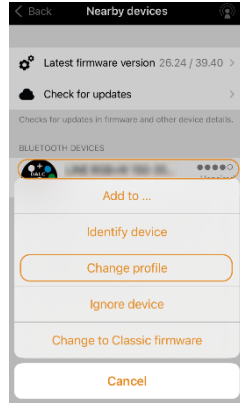

3. Tap on device's icon, then tap on *Unpair*.
4. Second tap on device's icon, then tap on *Change profile*.

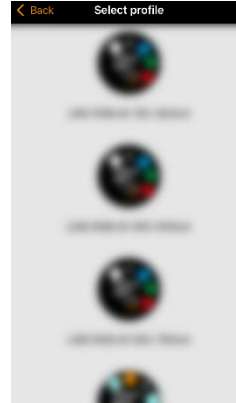

5. Select the desired profile (refer to Table 13).

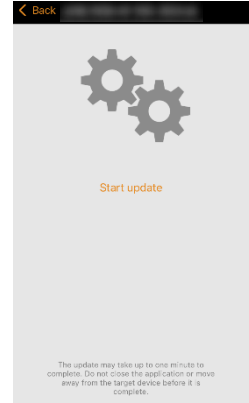

6. Tap *Start Update*.

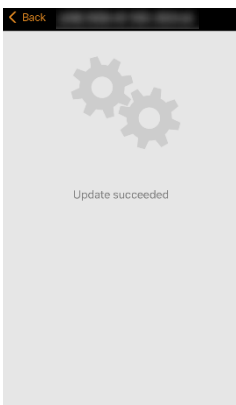

7. Wait for the profile to load correctly.
8. Back to *Nearby Devices* and select *Add to 'Network name'* to pair on the previous Network.

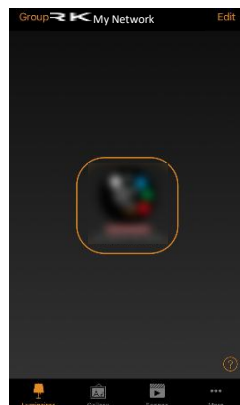

9. Once the device has been added to the Network, go back to *Luminaires* sheet and double tap on the profile icon to show the device configuration.

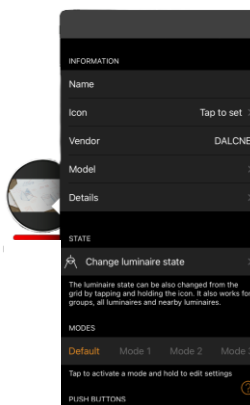

10. Hold tap on profile icon to show the profile settings.

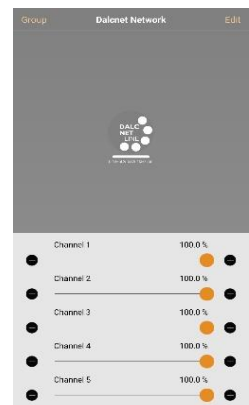

11. Inside the fixture configuration, the DMX profile (including the starting address) can be customized by the provided sliders/buttons.

## FIRMWARE UPDATE ON PAIRED DEVICE

From CASAMBI® mobile app it is possible to update the device's firmware. To check and load any update to the SLIM-CBU-DMX, follow these steps.



1. Power ON the device and open the CASAMBI® mobile app.
2. Select *Nearby Devices, More* sheet, then tap the Meatball menu ☰ and *Check for updates*.

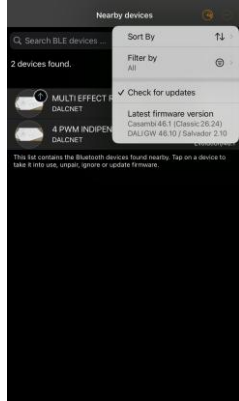

3. After checking for updates, if an update is available a small upward arrow will appear on device icon. Tap on device icon, then select *Update vendor firmware*.

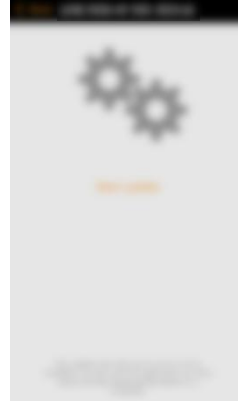

4. Tap *Start Update* on the next page. The transfer of the new Firmware will start.

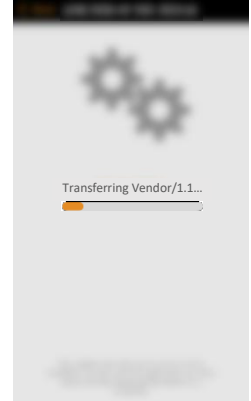

5. Please wait for the update, it may take up to three minutes or so.

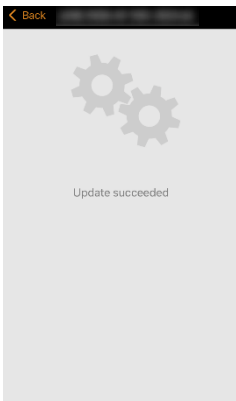

6. After the update and verification are successful, return to *Luminaires* sheet. Previous profile will be loaded.

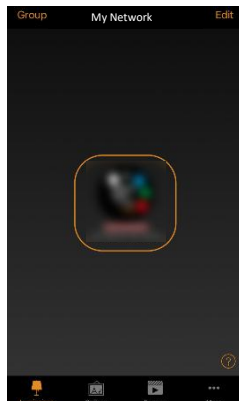

7. Double tap on the profile icon to show the device configuration settings.

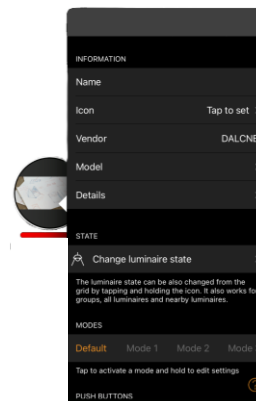

8. Tap on *Details* to show the device info.

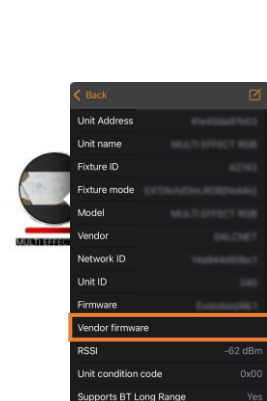

9. The firmware version can be viewed under *Vendor Firmware* item.